

MAN L21/31DF-M GenSet

9,50-1,881 kW

The MAN methanol-fuelled engine is a compact and reliable power source designed to run on methanol, heavy fuel oil (HFO), and most biofuels.

With its outstanding load-step capabilities and extremely long time between overhauls (TBO), this engine is ideal for many different applications.

Benefits at a glance

- Can operate on methanol and biofuels
- Long time between overhauls
- No unscheduled maintenance and repair work
- Low fuel and lube oil consumption while fulfilling legal emission limits
- Short installation length
- State-of-the-art SaCoS automatic controller

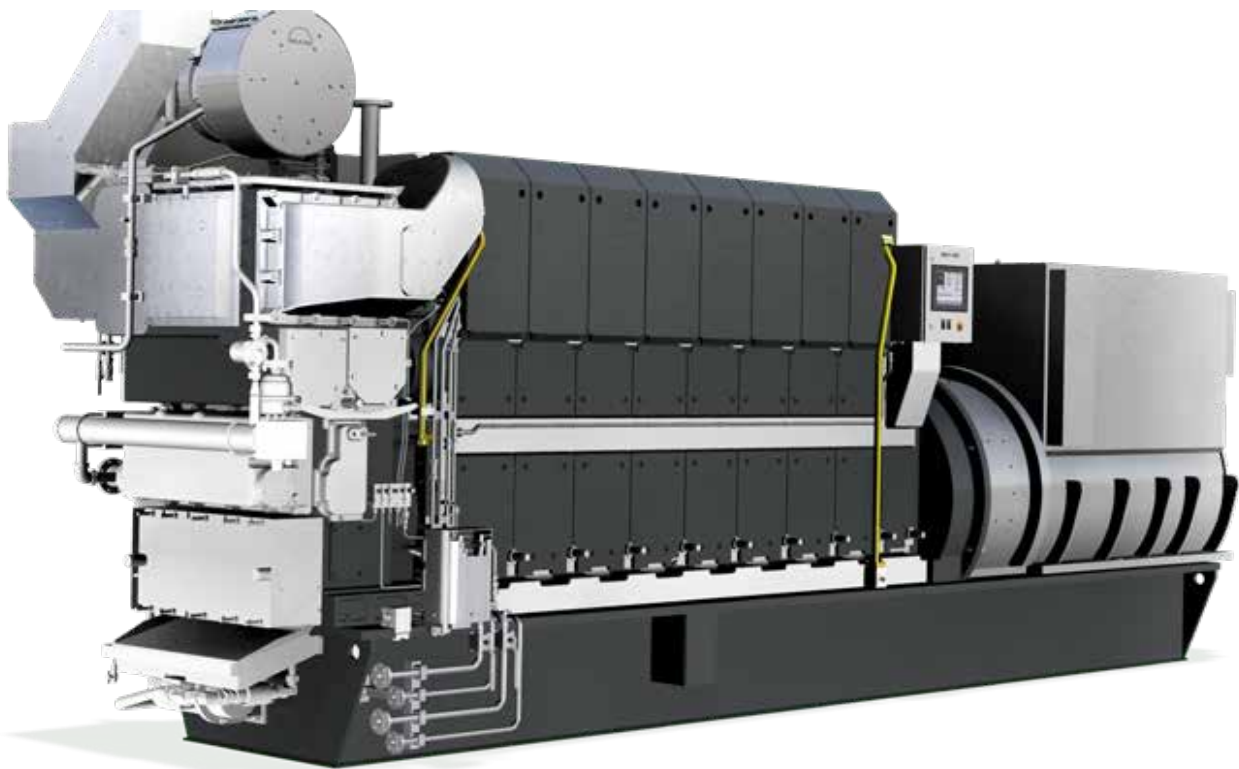



MAN L21/31DF-M

GenSet

Dimensions

Cyl. No.		5	6	7	8	9
A	mm	3,504	3,859	4,214	4,624	4,979
B	mm	1,995	2,047	2,027	2,577	2,657
C	mm	5,499	5,906	6,241	7,201	7,636
H	mm	3,074	3,161	3,161	3,267	3,267
Dry mass	t	22.2	25.7	29.2	32.7	36.2

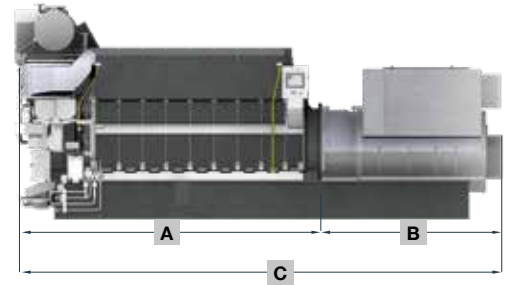

Output

Speed	rpm	1,000	1,000	900	900
Frequency	Hz	50	50	60	60
		Eng.	Gen.*	Eng.	Gen.*
MAN 5L21/31DF-M	kW	1,000	950	1,000	950
MAN 6L21/31DF-M	kW	1,320	1,255	1,320	1,255
MAN 7L21/31DF-M	kW	1,540	1,465	1,540	1,465
MAN 8L21/31DF-M	kW	1,760	1,675	1,760	1,675
MAN 9L21/31DF-M	kW	1,980	1,880	1,980	1,880

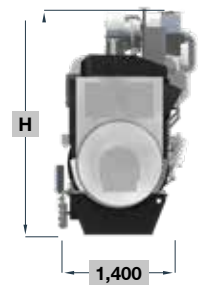

*Based on nominal generator efficiencies of 95 %

General

- Engine cycle: four-stroke
- No. of cylinders: 5, 6, 7, 8, 9
- Bore: 210 mm – Stroke: 310 mm
- Swept volume per cyl: 10.74 dm³

Fuel consumption at 85 % MCR

- SFOC: 183 g/kWh at 85% load
- SFOC for part-load-optimized version: 180 g/kWh at 75% load

Cylinder output (MCR)

- At 900/1000 rpm
220 kW/cyl for 6-9 cylinders
(200 kW/cyl for 5 cylinders)
- Power-to-weight ratio:
18.4 – 22.5 kg/kW

Compliance with emission regulations

- IMO Tier II
- IMO Tier III (with MAN SCR)

Main features

Turbocharging system

- High efficiency constant pressure MAN TCR series exhaust turbocharging system jet assist for improved load response and start up time

Engine automation and control

- MAN in-house developed engine attached safety and control system MAN SaCoS

Fuel system

- Conventional main injection system
- Methanol Port Injection acc to IGF code
- Fuel injection system adjusted for lowest fuel consumption while meeting IMO Tier II emission limits

Cooling system

- 1-string high and low temperature cooling water systems

Starting system

- Pressurized air starter (turbine type)

Engine mounting

- Common base frame for engine and alternator with integrated lube oil service tank and resilient mounting

Engine design

- “Pipeless engine” design
- Cooling water/lube oil pumps, thermostatic valves integrated in the front-end box

Optional equipment

- 100 % PTO on front-end with build-in bearing enable fire-fighting equipment (Fi-Fi)

MCR = Maximum continuous rating
SCR = Selective catalytic reduction
SFOC = Specific fuel oil consumption

MAN Energy Solutions

URL: <http://www.soar.hk>
E-mail: sale@soar.hk
Phone: +86-4008111308